

BeagleBone black WIFI enclosures

Product overview

- Designed to house the BeagleBone Black WIFI PCB, via clip-in grooves - **NO SCREWS REQUIRED!**
- All cut-outs are pre-cut into the case - **NO MODS REQUIRED!**
- Wall mountable
- Supplied with four rubber feet
- Latchable slide on clear cover

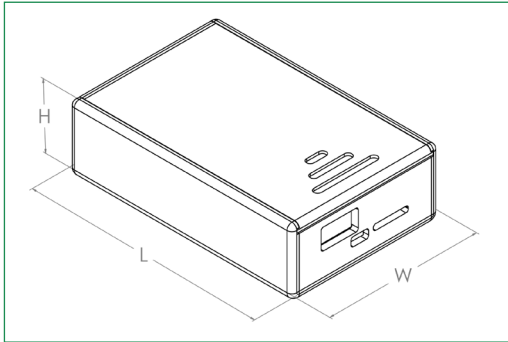

PART NO.	COLOUR	LENGTH	WIDTH	HEIGHT
CBBBKWIFI-CLR	Black	91mm	60mm	27mm

Material

- Coloured materials: High impact polystyrene (HIPS)
- Clear: PETg
- Thickness 3mm: HB rated

KEY FEATURES

Wall mountable | High gloss finish | Slide on clear cover

